

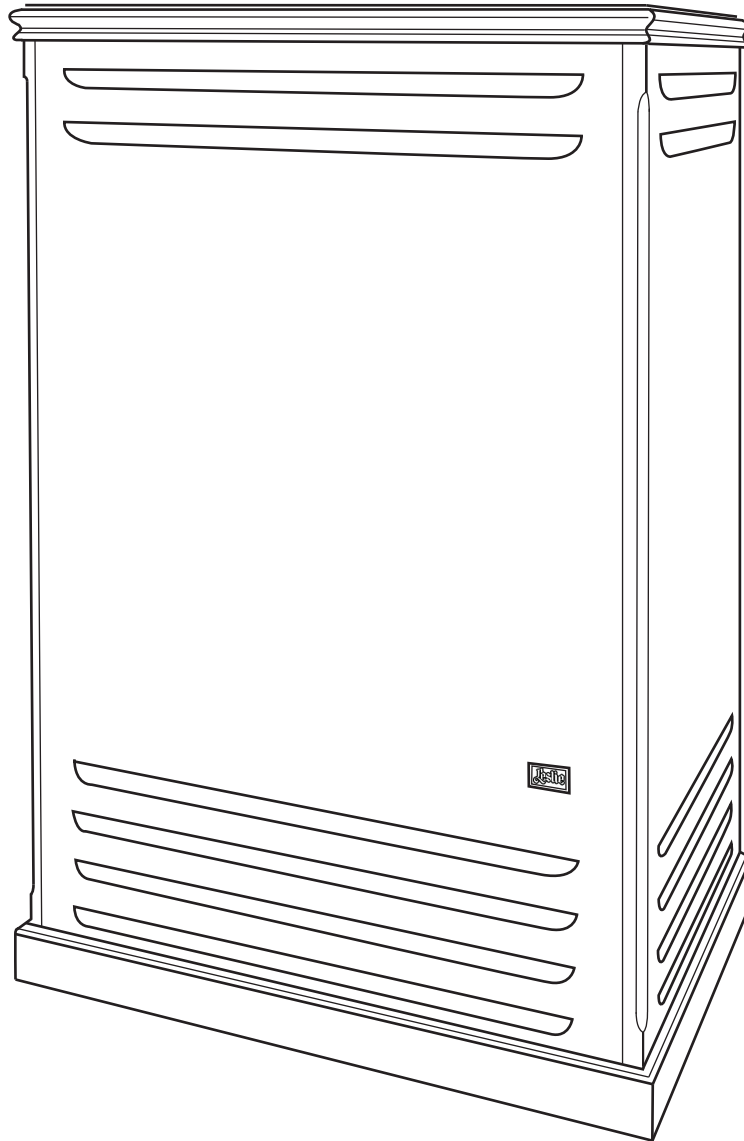

Innovative Sound Systems



Owners Manual

Models 122A / 122XB / 147A

IMPORTANT SAFETY INSTRUCTIONS

Read these instructions.

Keep these instructions.

Heed all warnings.

Follow all instructions.

Do not use this apparatus near water.

Clean only with dry cloth.

Do not block any ventilation openings. Install in accordance with the manufacturer's instructions.

Do not install near any heat sources such as radiators, heat registers, stoves or other apparatus (including amplifiers) that produce heat.

Do not defeat the safety purpose of the polarized or grounding type plug. A polarized plug has two blades with one wider than the other. A grounding type plug has two blades and a third grounding prong. The wider blade or third prong is provided for your safety. If the provided plug does not fit into your outlet, consult an electrician for replacement of the obsolete outlet.

Protect the power cord from being walked on or pinched, particularly at plugs, convenience receptacles, and the point where they exit from the apparatus.

Only use attachments/accessories specified by the manufacturer.

Use only with the cart, stand, tripod, bracket, or table specified by the manufacturer, or sold with the apparatus. When cart is used, use caution when moving the cart/apparatus combination to avoid injury from tip-over.

PORTABLE CART WARNING



Unplug this apparatus during lightning storms or when unused for long periods of time.

Refer all servicing to qualified service personnel. Servicing is required when the apparatus has been damaged in any way, such as power-supply cord or plug is damaged, liquid has been spilled or objects have fallen into the apparatus, the apparatus has been exposed to rain or moisture, does not operate normally, or has been dropped.

Apparatus shall not be exposed to dripping or splashing and no objects filled with liquids, such as vases, shall be placed on the apparatus.

WARNING: To reduce the risk of fire or electrical shock, do not expose this apparatus to rain or moisture.

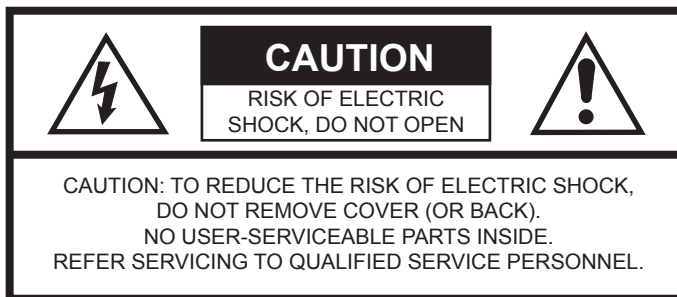

This symbol indicates that dangerous voltage constituting a risk of electric shock is present within this unit.



This symbol indicates there are important operating and maintenance instructions in the literature accompanying this unit.

Thank You!

We greatly appreciate your purchase of a new Leslie speaker system. If this is your first purchase of a Leslie product, we would like to welcome you into the Leslie family. If you are a repeat customer, thank you for your continued confidence in our Leslie products.

Your new Leslie speaker system was engineered and manufactured to the most stringent-quality standards, reproducing the full-spectrum sound of musical instruments and housed in acoustically-engineered, fine furniture-like cabinet. This will assure that your new Leslie will sound and look great for many years to come. Your Leslie speaker culminates many years of research and dedication to the art of sound reproduction and is carefully designed and tested to provide long dependable service.

Many features have been included in this speaker to insure the finest sound from your organ or keyboard product. Please take a moment to carefully read this manual and familiarize yourself with many of the fine features found in your new Leslie speaker system. Take pride in being the owner of the most innovative sound system in the industry today.

Product Overview

Your new Leslie speaker system contains two rotors to produce the world-renowned “Sound-In-Motion” effect. The upper frequencies are reproduced by the high-compression driver and a custom-molded rotary horn. The lower frequencies radiate from the massive 15” woofer and the high-density custom-molded foam drum. The rotors can be operated in *Fast* (Tremolo) or *Slow* (Chorale) modes. Our model 122XB Leslie also features an *Off* mode (rotors stopped).

The model 122A Leslie is specifically designed for older Hammond organs such as Hammond organ models A, B, C, and RT, that require a separate tone cabinet for sound reproduction. The Leslie 122A is provided with a 6-pin Leslie connector to facilitate easy connection to these Hammond organ products when used with the proper interface kit (available at your local Leslie dealer). A Master Volume control, which is located on the top of the power amplifier, is also provided.

The model 147A Leslie, which shares the same cabinet design as the Leslie 122A, is recommended for single-channel organs with self-contained speaker systems, such as Hammond organ model A-100 and spinet models such as M, M-2, M-3, M-100 and L-100. In addition to the 6-pin Leslie connector and Master Volume control, the 147A also contains an Input Selector switch which is located to the left of the Master Volume control on the top of the power amplifier. This switch is used to electrically match the impedance of your organ speaker system. We strongly recommend that a factory-trained technician set the position of this switch.

The Leslie 122XB is electrically identical to the model 122A, except that it contains an 11-pin Leslie connector. The Leslie 122XB is designed to interface with newer Hammond organs and keyboards like the New B-3, Traditional and Pro XK Systems, and our XK-3c keyboard, that contain an 11-pin Leslie connector. For more connectivity, the Leslie Interface Panel - with 1/4” Line Input jack, 1/4” foot switch jack, and an AC power switch - is an optional accessory to add to the 122XB.

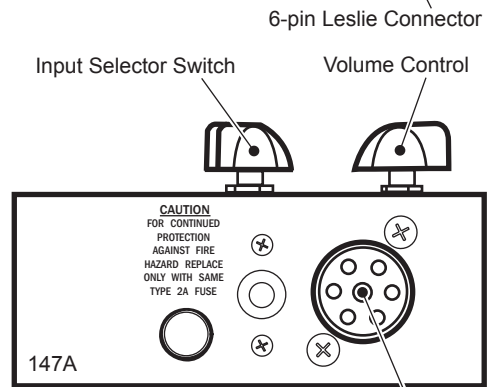
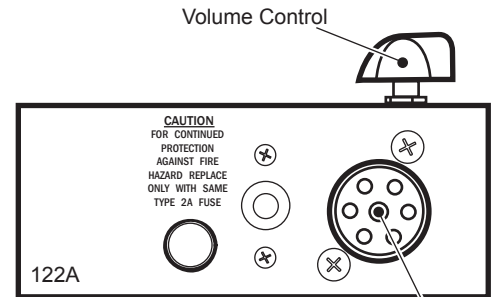
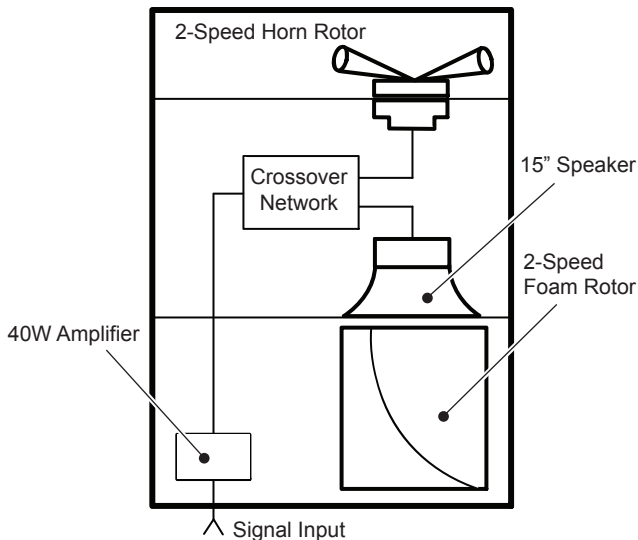
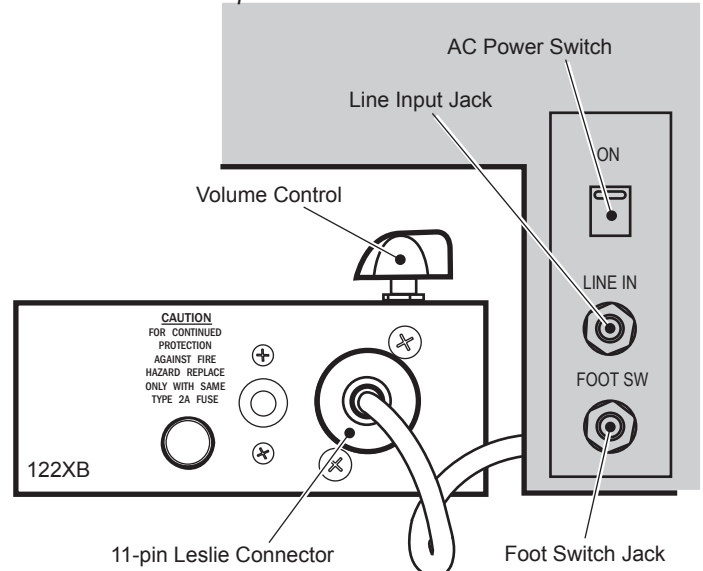

Diagram of Models 122A, 122XB, 147A



Optional Leslie Interface Panel



Leslie Setup Procedure

In most cases, your local Leslie dealer will connect your new Leslie speaker to your organ or keyboard product. In the case that no setup was provided or if you wish at a later time to move your Leslie speaker to another location, please carefully read and follow the setup procedure below:

1. Place your Leslie speaker in a location that produces the best sound reproduction.
2. If you wish to connect your Leslie by means of the Leslie cable provided, carefully plug the male end of the Leslie cable assembly into the female socket located on your organ or keyboard. If you are using a 6-pin cable assembly (Leslie models 122A & 147A), make sure that all the pins on the plug align perfectly with those on the female socket before plugging in the cable. If you are using an 11-pin cable assembly (Leslie 122XB), make sure that the key on the male plug aligns with the key on the female socket before plugging in the cable. On Leslie 122XBs with the optional Leslie Interface Panel, you have the option of connecting your organ or keyboard to your Leslie 122XB by means of a cable with 1/4" plug on both ends (not provided). Plug one end of the cable assembly into the Line Output jack on your organ or keyboard, and the other end to the Line Input jack on the Leslie. Then proceed to step 4.
3. Repeat the above procedure to connect the other end of the Leslie cable to the Leslie speaker.
4. On Leslie 122XBs, plug the AC power cord into a 120V AC outlet.
5. Turn the volume control (located on top of the power amplifier) to the fully counterclockwise position.
6. If you are connecting a Hammond organ to your Leslie, pull all the upper and lower drawbars including the pedal drawbar fully out (#9 positions). Set the expression pedal to the loudest position (fully depressed). For non-Hammond products, set the volume control to the loudest position and set the voice registration to a setting that provides maximum sound (i.e. Full organ).
7. Turn on the power switch on your organ or keyboard and on your Leslie 122XB when using the 1/4" Line Input jack. For organs, play a three-note chord on the upper and lower manuals and depress the low "C" pedal. For keyboards, place the unit in the split keyboard mode and play a three-note chord on the upper manual and the low "C" pedal note. Have someone slowly turn the volume control clockwise on the Leslie until the sound begins to distort, then slowly decrease the volume (turn the control counterclockwise) until the sound is undistorted. Your Volume Control is now properly set.

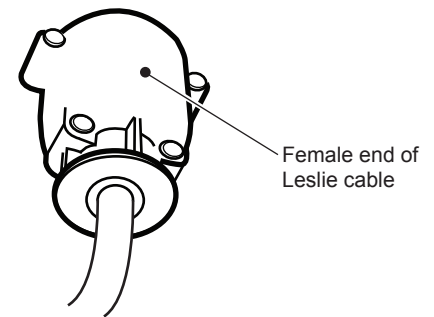
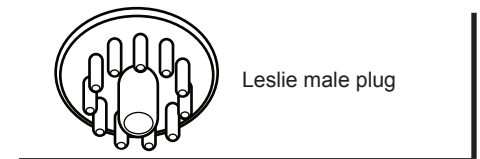
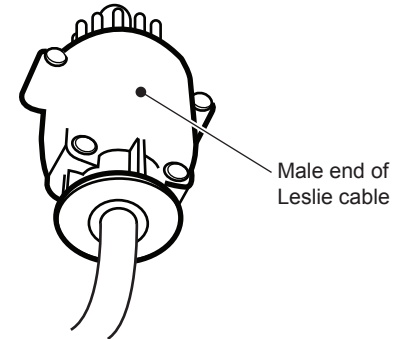
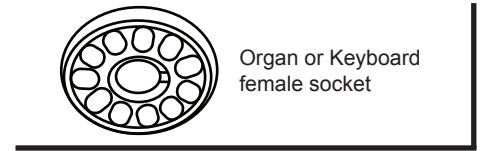

Caution: Do not play your Leslie at a volume setting that produces a distorted sound. Severe damage may occur to your new Leslie if played in this condition for an extended period of time.

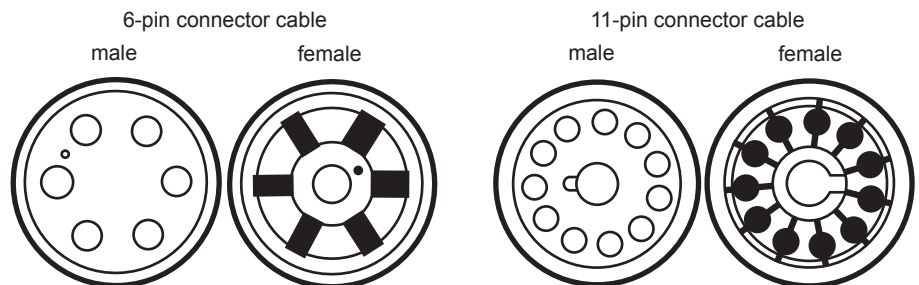

Where to place your new Leslie Speaker System

One of the first considerations will be where to place the speaker for the best all-around effect. Most musicians prefer having the Leslie speaker near the organ or keyboard product so that the sound is balanced to their desired level. Closer or more distant locations are easily accommodated by adjusting the volume level of the speaker (see page 4 Leslie Setup Procedure).

Whatever the distance from the keyboard, the Leslie speaker should be given enough space so the sound can radiate fully through the room. Restricting the sound dispersal by placing the cabinet against a wall or between large pieces of furniture reduces the effectiveness of the speaker. Sound reflection is desirable. Yet in most homes, much sound is absorbed by furniture, rugs and drapes, rather than being reflected. The Leslie speaker overcomes this absorption problem by providing a moving-sound source. Placing the speaker diagonally in a corner is a good practice. Sound will be reflected off the two adjacent walls, enhancing the beauty, power and dispersion of the music.

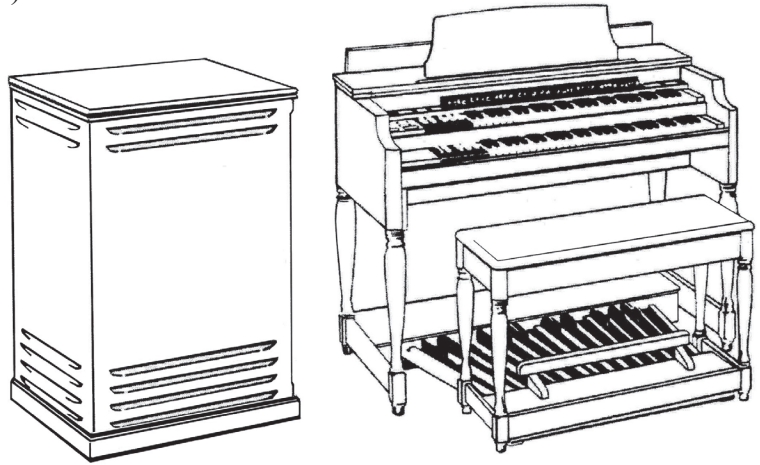

Care of your new Leslie Speaker

Your new Leslie speaker has been carefully engineered for durability and maximum service. Except for occasional replacement of maintenance items such as belt and vacuum tubes, your new Leslie speaker will require little or no attention.

CAUTION

As with any electrical or electronic equipment, care should be exercised to prevent fire and shock hazard. The following information is provided to give guidance in the safe use and care of your Leslie Speaker.

ENVIRONMENT

This speaker is primarily designed to be used in an interior environment. To prevent an electrical shock hazard, do not expose your Leslie to wet floors, liquid spills and splashes, or rain.

ENCLOSURE

The removal of any part of the enclosure may result in exposure to electrical shock. Servicing should not be attempted by the user; refer all servicing to factory-trained technicians.

POWER

Operate this speaker only at the AC voltage and frequency indicated on the nameplate located on the back of the Leslie.

CLEANING THE CABINET

Use a soft cloth or chamois, slightly dampened with water. A little mild detergent may be added to the water if necessary. For the Leslie models finished in red walnut, rub lightly with the grain of the wood. Excessive rubbing in one spot or at the edge of the cabinet may damage the finish. Use a good grade of furniture wax or polish.

MOVING OR RELOCATING YOUR LESLIE SPEAKER

So as not to damage your Leslie cables, carefully unplug both ends of the cable before moving your Leslie speaker. To prevent damage to the cabinet, it is advisable that more than one person move the speaker.

PACKING AND SHIPPING

Packing and shipping should be done by your local Leslie dealer or by a qualified mover. The speaker should not be moved or carried on its side or upside down, as this will result in damage to the moving parts inside the cabinet. The cabinet must be moved, carried or shipped in an upright position. The exterior should be protected by boxing the cabinet or covering it with padding.

SPECIFICATIONS:

Leslie models 122A, 122XB, 147A

- Single-Channel Input
- Amplifier: 40Watt RMS Vacuum tube amplifier
- Two speed horn and drum rotor
- Inputs: Model 122A, 147A – 6-pin Leslie connector
Model 122XB- 11-pin Leslie connector, With Optional Panel: 1/4" Line Input jack and 1/4" foot switch jack
- Controls: Model 122A – Master Volume control
Model 147A – Master Volume control, Input Selector switch
Model 122XB – Master Volume control
- Speakers: Massive 15" woofer, high-compression horn driver
- Dimensions: 41 5/8" H, 29 1/4" W, 20 5/8" D
- Weight: 149 lbs

OPTIONAL ACCESSORIES

Shown below are only a few of the available optional accessories for your new Leslie Speaker. Visit our website or your local Leslie dealer to view all the available products to enhance your Leslie Speaker.

Model FS-10TL Foot Switch

Enable the selection of speeds on the 122XB Leslie. Supplied with a 16' cord with a 1/4" plug. For use with optional Leslie Interface Panel.



Tremolo / Chorale Switch

This half-moon shaped switch assembly is used to control the speeds of the Leslie speaker. Consult your dealer for the switch that your organ or Leslie requires.



6-pin and 11-pin Leslie cable assemblies

These cable assemblies are available in 30', 50' and 100' lengths.



Leslie Power Relay

This adapter will allow you to connect additional Leslie speakers to your organ. One is needed for each additional speaker.





SERVICE

Hammond maintains a policy of continuously improving and upgrading its instruments and therefore reserves the right to change specifications without notice.

Although every attempt has been made to insure the accuracy of the descriptive contents of this manual, total accuracy cannot be guaranteed.

Should the owner require further assistance, inquiries should first be made to your Authorized Hammond Dealer.

If you still need further assistance, contact Hammond at the following address.

Hammond USA

743 Annoreno Drive

Addison, IL 60101

Phone: 1-888-ORGAN B3

Fax: 630-543-0279

Visit our website

www.hammondorganco.com